

Variable Magnification Lens 2/3" Format

Item No.MQL6000

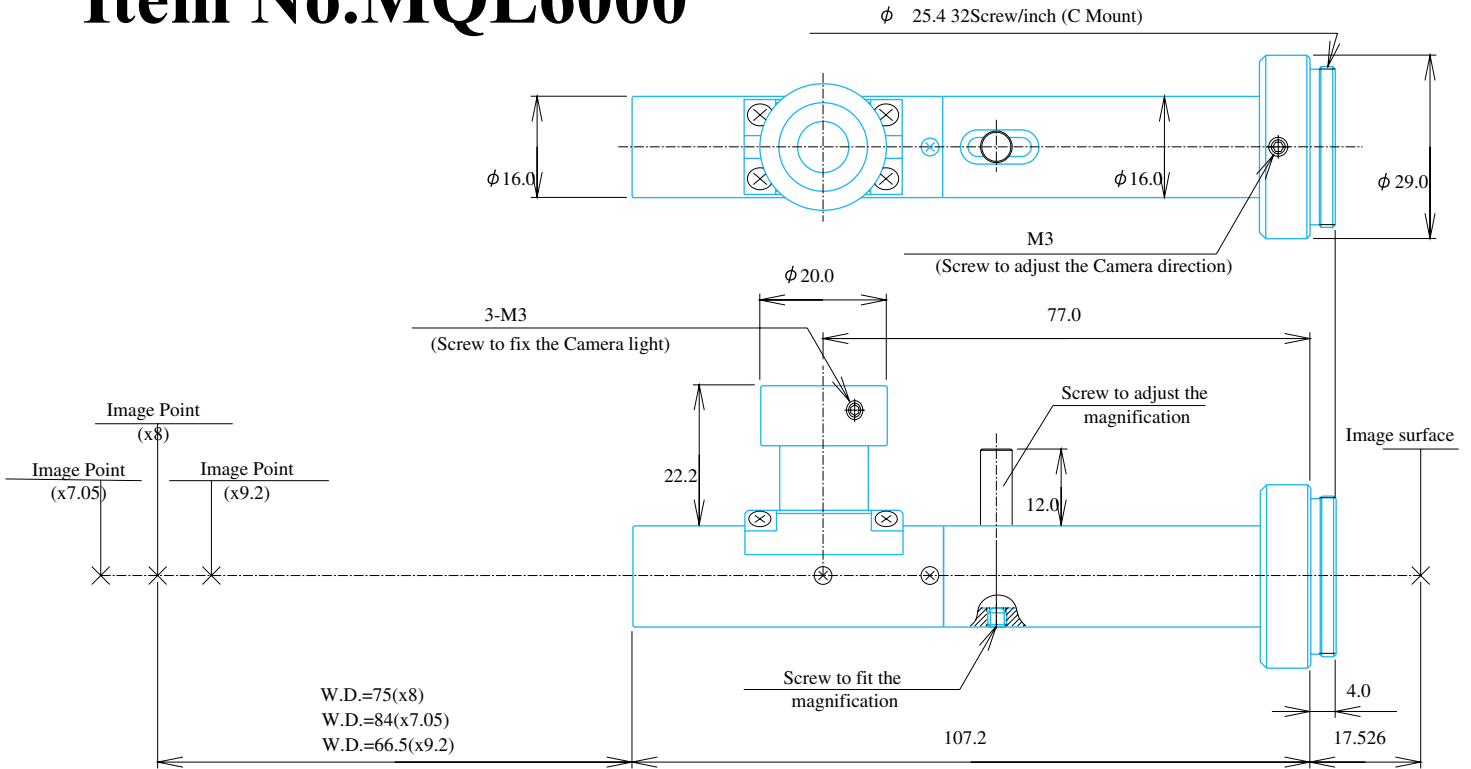

ITEM NO.	MQL6000
W.D.	84 - 67 (mm)
MAGNIFICATION	x7.3 - 9.0
APERTURE	F48 - F60
DEPTH OF FIELD	+/-0.06 (x8.00) (mm)
OBJECT SIZE	0.9 x 1.2 - 0.7 x 1.0 (mm)
IMAGE SIZE	6.6 x 8.8 (mm)
RESOLUTION POWER	4 - 3 (μ m)
NA	0.076 (%)
TV DISTORTION	0.20 (%)
NOTES	Coaxial

GOYO OPTICAL Inc.

Japanese Office

3-8-31 HAMAZAKI,
 ASAKA,
 SAITAMA 351-0033,
 JAPAN,
 TEL:048-474-2235
 FAX:048-474-7373
 E-MAIL:info@goyooptical.com

German Office

KURHAUSSTR,3
 ROOM N'19
 D-55543 BAD KREUZNACH
 GERMANY
 TEL:0671-4822255
 FAX:0671-43603
 E-MAIL:info@goyooptical.com